

Unit 15

Objective 12

Assignment Sheet 1—Identify Components on HVACR System Electrical Diagrams

Name _____ Overall Rating _____

Date _____

Evaluation Criteria	Rating
• Number of answers completed	_____
• Number of correct answers	_____

Basic Skills



Reading



Writing



Critical
Thinking

Directions

Reference the accompanying HVACR system electrical diagrams to answer the following questions.

- a. What are the power sources?

- b. What are the system loads?

- c. What switches are in the contactor coil circuit?

Assignment Sheet 1

- d. What are the names of the motors and how many switch contacts control each motor?

- e. Do the blower relay contacts control the hot leg or the neutral leg?

- f. What loads are in series when the thermostat is calling for heating?

- g. What load is parallel to the start relay coil?

Assignment Sheet 1

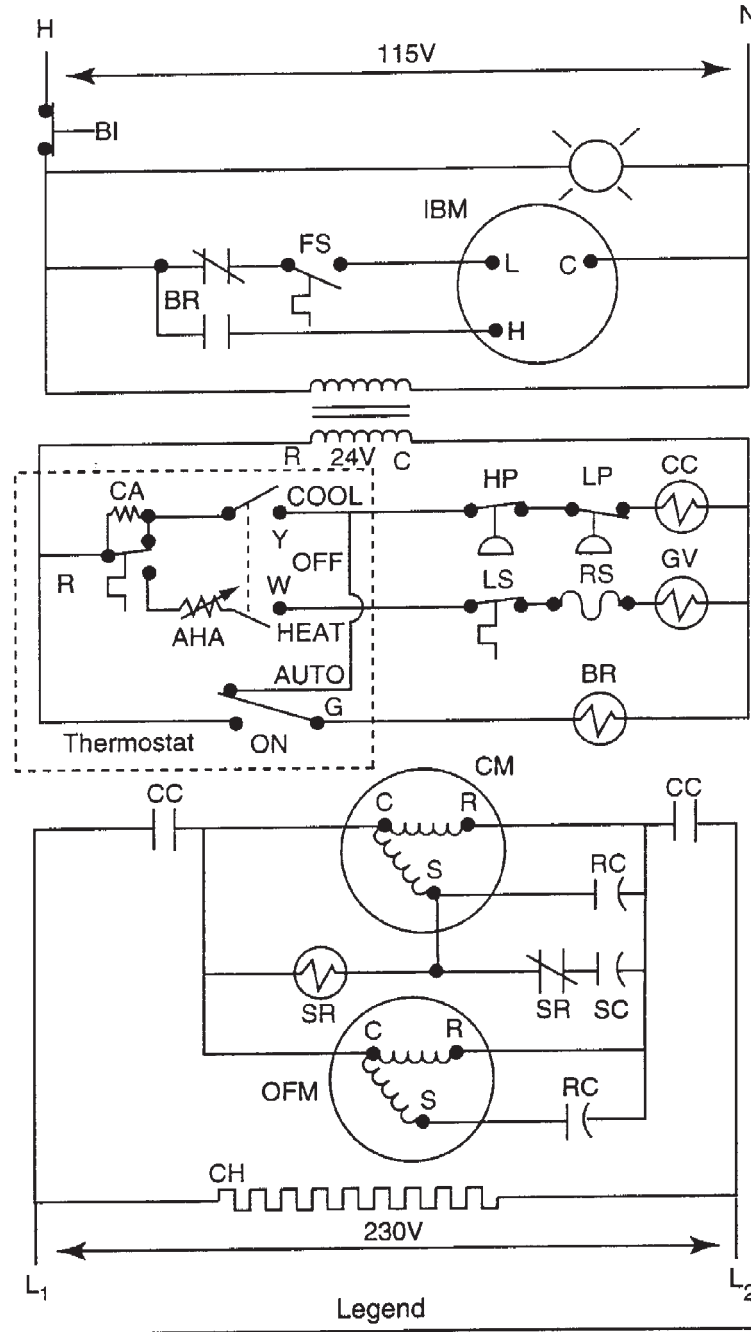

- Legend
- | | |
|--------------------------------------|---------------------------|
| AHA — Adjustable heating anticipator | HP — High-pressure switch |
| BI — Blower door interlock | IBM — Indoor blower motor |
| BR — Blower relay | LP — Low-pressure switch |
| CA — Cooling anticipator | LS — Limit switch |
| CC — Cooling contactor | OFM — Outdoor fan motor |
| CH — Crankcase heater | RC — Run capacitor |
| CM — Compressor motor | RS — Rollout switch |
| FS — Fan switch | SR — Start relay |
| GV — Gas valve | SC — Start capacitor |

Unit 15

Objective 13

Assignment Sheet 2—Identify Component Operations From HVACR System Electrical Diagrams

Name _____ Overall Rating _____

Date _____

Evaluation Criteria	Rating
• Number of answers completed	_____
• Number of correct answers	_____

Basic Skills



Reading



Writing



Critical
Thinking

Directions

Reference the accompanying HVACR system electrical diagrams to answer the following questions.

- a. Assuming the blower door is closed and the light is functional, will the indoor blower motor operate if the light is not on? _____ Why or why not?

- b. What effect will energizing the compressor contactor have on the crankcase heater?

- c. With the thermostat calling for cooling, what effect will an open low-pressure switch have on the indoor blower motor?

- d. What is disconnected when the start relay is energized?

Assignment Sheet 2

- e. What switches must be closed to energize the indoor blower motor low-speed?

- f. What switches or other components could be open if 24V is available from the transformer but is not available at the gas valve?

- g. What switches could the 24V go through to reach the blower relay coil?

Assignment Sheet 2

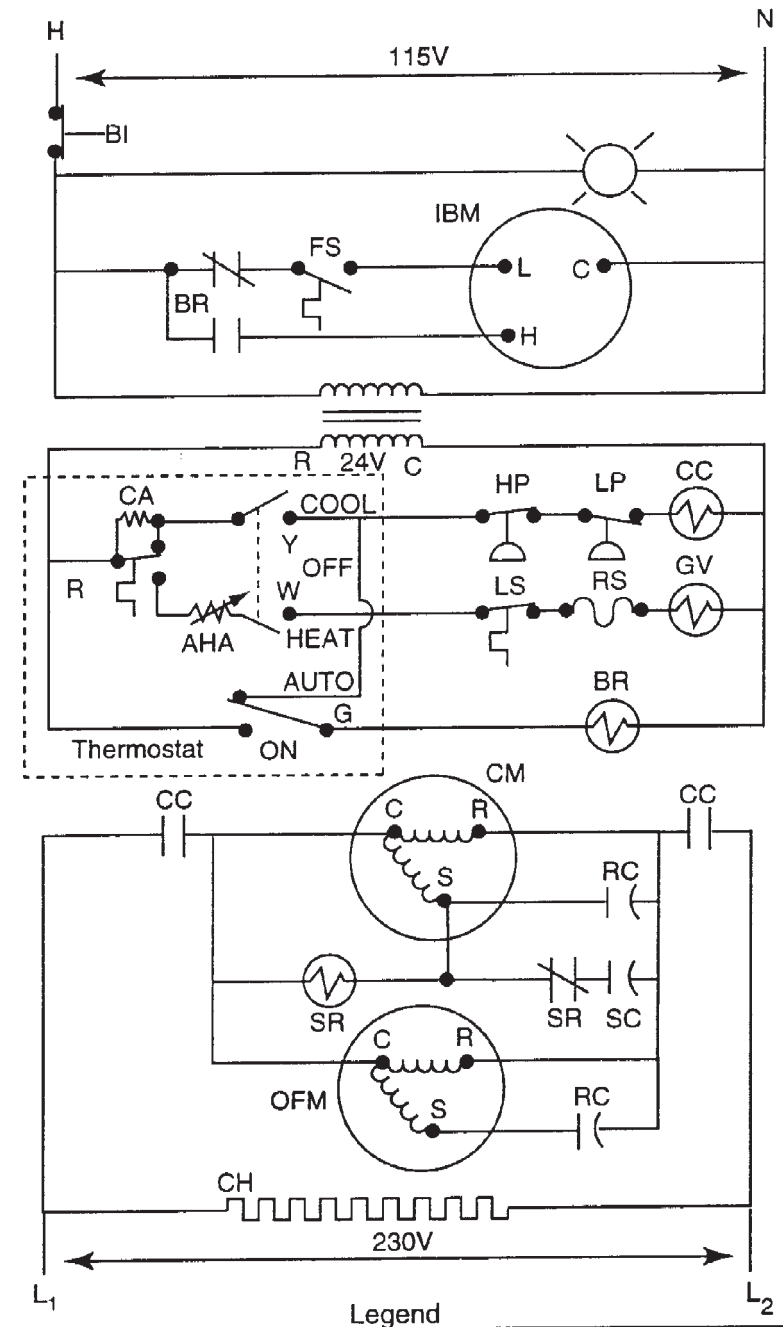

- | | |
|---|--|
| <p>AHA — Adjustable heating anticipator</p> <p>BI — Blower door interlock</p> <p>BR — Blower relay</p> <p>CA — Cooling anticipator</p> <p>CC — Cooling contactor</p> <p>CH — Crankcase heater</p> <p>CM — Compressor motor</p> <p>FS — Fan switch</p> <p>GV — Gas valve</p> | <p>HP — High-pressure switch</p> <p>IBM — Indoor blower motor</p> <p>LP — Low-pressure switch</p> <p>LS — Limit switch</p> <p>OFM — Outdoor fan motor</p> <p>RC — Run capacitor</p> <p>RS — Rollout switch</p> <p>SR — Start relay</p> <p>SC — Start capacitor</p> |
|---|--|

Objective 14

Assignment Sheet 3—Select Test Instruments or Procedures for Specific HVACR System Troubleshooting

Name _____ Overall Rating _____

Date _____

Evaluation Criteria	Rating
• Number of answers completed	_____
• Number of correct answers	_____

Basic Skills



Reading



Writing



Critical
Thinking

Directions

Reference the accompanying HVACR system diagrams and select test instrument(s) and/or procedure(s) to answer the following questions.

Example: Is potential available to the indoor blower motor?

Turn thermostat automatic on switch to on; if blower runs voltage is available, or

Check light; if light is burning, power is available to the indoor blower motor, or

Use a voltmeter with probes at neutral and the outlet side of the blower interlock switch.

a. Is potential available to the compressor contactor contacts?

b. (1) Are the blower relay normally open contacts open as determined by using the hopscotch method?

Assignment Sheet 3

(2) Are the blower relay normally open contacts open as determined by using other than the hopscotch method?

c. Are the outdoor fan motor windings open?

d. Is the crankcase heater operating?

e. Will the compressor run after you find an open high pressure switch?

Assignment Sheet 3

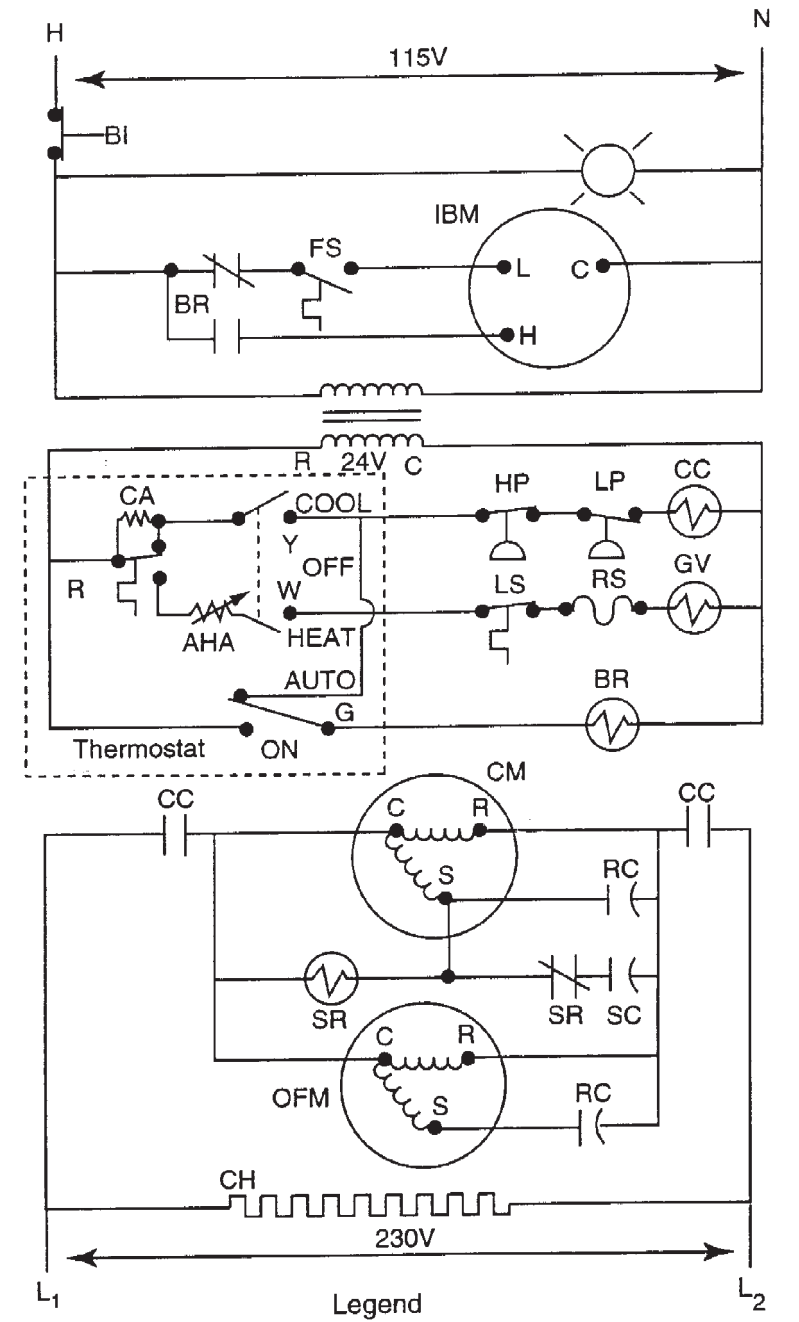

- | | | | |
|-----|----------------------------------|-----|------------------------|
| AHA | — Adjustable heating anticipator | HP | — High-pressure switch |
| BI | — Blower door interlock | IBM | — Indoor blower motor |
| BR | — Blower relay | LP | — Low-pressure switch |
| CA | — Cooling anticipator | LS | — Limit switch |
| CC | — Cooling contactor | OFM | — Outdoor fan motor |
| CH | — Crankcase heater | RC | — Run capacitor |
| CM | — Compressor motor | RS | — Rollout switch |
| FS | — Fan switch | SR | — Start relay |
| GV | — Gas valve | SC | — Start capacitor |

Unit 15

Objective 15

Assignment Sheet 4—Solve HVACR Electrical Troubleshooting Problems

Name _____ Overall Rating _____

Date _____

Evaluation Criteria	Rating
• Number of answers completed	_____
• Number of correct answers	_____

Basic Skills



Reading



Writing



Critical
Thinking

Directions

Reference the accompanying HVACR system electrical diagrams to solve the following questions.

- a. A customer complains of no cooling. Upon arrival at the location, you observe that the thermostat is set to call for cooling and automatic fan operation, but nothing is running. You set the thermostat fan switch to the ON position and the indoor blower motor starts and runs normally.

What specific component could cause the conditions observed?

What would you recommend to correct the problem?

- b. A customer complains of no cooling. Upon arrival at the location, you observe both fans running, but the compressor is not running.

Assuming there are no broken wires, what components could cause the problem?

Assignment Sheet 4

- c. A customer complains of no heat. Upon arrival at the location, you observe that the thermostat is set to call for heat but nothing is running. A voltmeter check reads 24V from W on the thermostat to C on the transformer, but a voltmeter check at the gas valve reads zero volts.

Excluding wiring or connections, what components could fail and cause the conditions observed?

- d. A customer complains of no heat. Upon arrival at the location, you observe that the thermostat is set to call for heat but nothing is running. You turn the fan switch to the ON position, but nothing happens. You open the electrical panel and observe the power light on.

What component should you check next?

- e. A customer complains of no heat. Upon arrival at the location, you observe that the thermostat is set to call for heat, but nothing is running. You set the fan switch to the ON position and the blower runs. Using the hopscotch method, you determine that the limit switch is open even though the furnace is obviously not overheated.

What can you do to determine if the furnace will work if you replace the limit switch?

- f. A customer complains of not enough cooling. Upon arrival at the location, you observe that the outdoor condensing unit is cycling on and off approximately every three to four minutes. After cleaning a dirty condenser coil, the system has normal operating pressures, but continues to cycle on and off. You determine that the high-pressure switch has failed.

What could you do to make the system operational until you can obtain a new high pressure switch?

Assignment Sheet 4

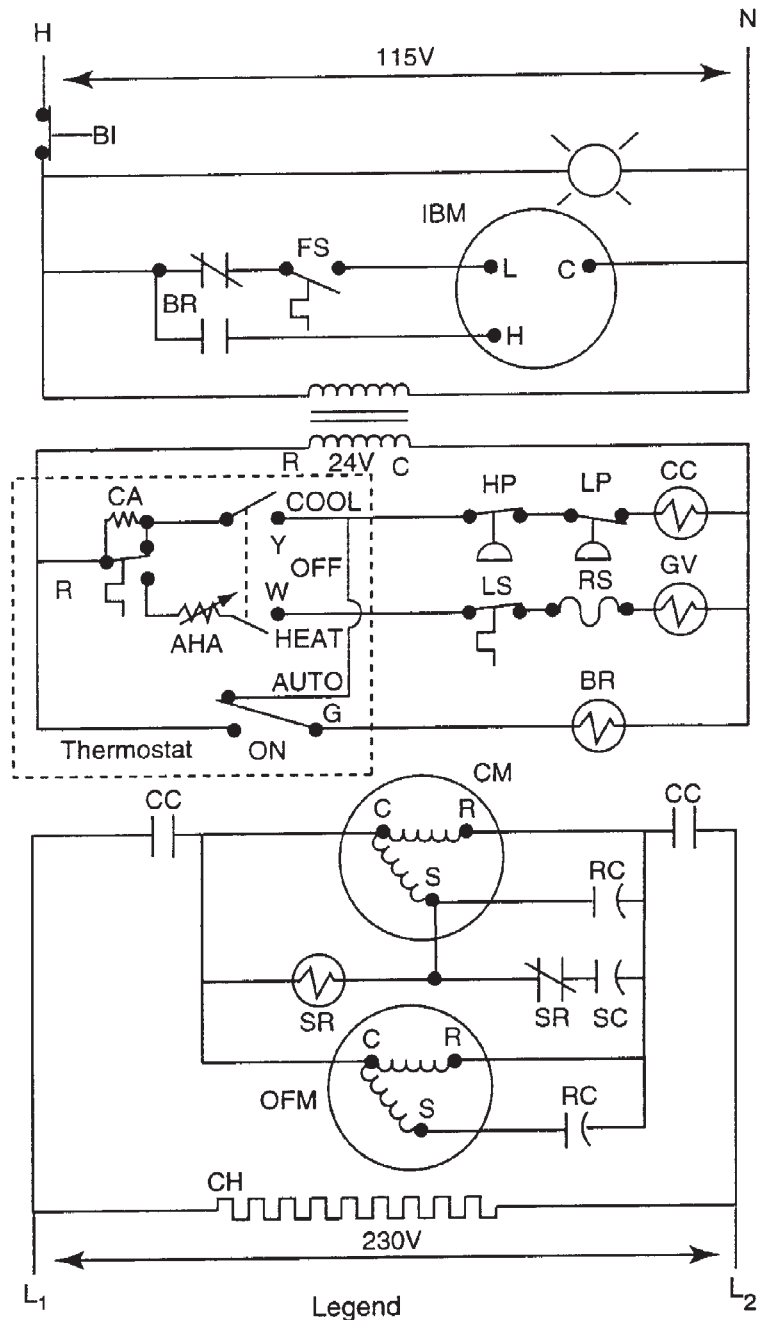

- | | |
|--|---|
| <p> AHA — Adjustable heating anticipator
 BI — Blower door interlock
 BR — Blower relay
 CA — Cooling anticipator
 CC — Cooling contactor
 CH — Cranks case heater
 CM — Compressor motor
 FS — Fan switch
 GV — Gas valve </p> | <p> HP — High-pressure switch
 IBM — Indoor blower motor
 LP — Low-pressure switch
 LS — Limit switch
 OFM — Outdoor fan motor
 RC — Run capacitor
 RS — Rollout switch
 SR — Start relay
 SC — Start capacitor </p> |
|--|---|

Objective 16

Job Sheet 1—Troubleshoot Series Electrical Circuits on Selected HVACR Equipment

Name _____ Overall Rating _____

Date _____

Evaluation Criteria	Rating
• Equipment operated for evaluation	_____
• Test instruments/procedures used to identify circuit problems	_____
• Correct action recommended and recorded	_____

Basic Skills



Reading



Science



Critical
Thinking



Employability



Technology

Instructions

When you are ready to perform this task, ask your instructor to observe the procedure and rate your performance using the evaluation criteria.

Tools, Equipment, and Materials

- Trainer or selected HVACR equipment with series electrical circuits
- HVACR technician's hand tools
- Safety glasses or goggles
- Test instruments as required

Procedure

✓ **Note:** Your instructor will provide you with series circuit(s) with faults inserted.

1. Put on safety glasses or goggles.
2. Remove panels or covers as needed to access components.
3. Use electrical diagrams and any other available information about this equipment to identify circuit components and their normal operation.
4. Operate circuit or equipment and observe normal operation.
5. Have your instructor insert fault(s).
6. Observe operation of equipment or circuit and compare with normal operation.

Job Sheet 1

- 7. Select appropriate test instrument(s) and procedure to evaluate the condition of the equipment.
- 8. Use your selected test instrument(s) and procedure to determine the cause of the circuit problem(s), and record your findings.

- 9. If you find an open, jumper the open to determine if there are any other problems.

✓ Note: While open loads are not normally jumpered, when loads are in series, an open load can be jumpered.
- 10. Record what corrective action you would recommend to make the circuit or equipment functional.

- 11. Have your instructor evaluate your findings.
- 12. Repeat the procedure for other problems as directed by your instructor.
- 13. Shut down equipment.
- 14. Clean up area and put tools away.

Evaluator's Comments:- _____

Troubleshooting HVACR System Electrical Circuits

Unit 15

Objective 17

Job Sheet 2—Troubleshoot Parallel Electrical Circuits on Selected HVACR Equipment

Name _____ Overall Rating _____

Date _____

Evaluation Criteria	Rating
• Equipment operated for evaluation	_____
• Test instruments/procedures used to identify circuit problems	_____
• Correct action recommended and recorded	_____

Basic Skills



Reading



Science



Critical
Thinking



Employability



Technology

Instructions

When you are ready to perform this task, ask your instructor to observe the procedure and rate your performance using the evaluation criteria.

Tools, Equipment, and Materials

- Trainer or selected HVACR equipment with parallel electrical circuits
- HVACR technician's hand tools
- Safety glasses or goggles
- Test instruments as required

Procedure

✓ **Note:** Your instructor will provide you with parallel circuit(s) with faults inserted.

1. Put on safety glasses or goggles.
2. Remove panels or covers as needed to access components.
3. Use electrical diagrams and any other available information about this equipment to identify circuit components and their normal operation.
4. Operate circuit or equipment and observe normal operation.
5. Have your instructor insert fault(s).
6. Observe operation of equipment or circuit and compare with normal operation.

Job Sheet 2

- 7. Select appropriate test instrument(s) and procedure to evaluate the condition of the equipment.
- 8. Use your selected test instrument(s) and procedure to determine the cause of the circuit problem(s), and record your findings.

- 9. If you find an open switch, safety device, or wire, jumper the open to determine if there are any other problems.

Caution: Jumpering an open load in a parallel circuit creates a direct short and will trip safetys and possibly damage components.

- 10. Record what corrective action you would recommend to make the circuit or equipment functional.

- 11. Have your instructor evaluate your findings.
- 12. Repeat the procedure for other problems as directed by your instructor.
- 13. Shut down equipment.
- 14. Clean up area and put tools away.

Evaluator's Comments:- _____

Troubleshooting HVACR System Electrical Circuits

Unit 15

Objective 18

Job Sheet 3—Troubleshoot Series-Parallel Electrical Circuits on Selected HVACR Equipment

Name _____ Overall Rating _____

Date _____

Evaluation Criteria	Rating
• Equipment operated for evaluation	_____
• Test instruments/procedures used to identify circuit problems	_____
• Correct action recommended and recorded	_____

Basic Skills



Reading



Science



Critical
Thinking



Employability



Technology

Instructions

When you are ready to perform this task, ask your instructor to observe the procedure and rate your performance using the evaluation criteria.

Tools, Equipment, and Materials

- Trainer or selected HVACR equipment with series-parallel electrical circuits
- HVACR technician's hand tools
- Safety glasses or goggles
- Test instruments as required

Procedure

✓ **Note:** Your instructor will provide you with series-parallel circuit(s) with faults inserted.

1. Put on safety glasses or goggles.
2. Remove panels or covers as needed to access components.
3. Use electrical diagrams and any other available information about this equipment to identify circuit components and their normal operation.
4. Operate circuit or equipment and observe normal operation.
5. Have your instructor insert fault(s).
6. Observe operation of equipment or circuit and compare with normal operation.

Job Sheet 3

- 7. Select appropriate test instrument(s) and procedure to evaluate the condition of the equipment.
- 8. Use your selected test instrument(s) and procedure to determine the cause of the circuit problem(s), and record your findings.

- 9. If you find an open switch, safety device, or wire, jumper the open to determine if there are any other problems.

Caution: Jumpering an open load in a parallel circuit creates a direct short and will trip safety devices and possibly damage components.

- 10. Record what corrective action you would recommend to make the circuit or equipment functional.

- 11. Have your instructor evaluate your findings.

- 12. Repeat the procedure for other problems as directed by your instructor.

- 13. Shut down equipment.

- 14. Clean up area and put tools away.

Evaluator's Comments:- _____
